

# **Waste Energy Recovery Opportunities for Interstate Natural Gas Pipelines**

*Prepared for:*



**Interstate Natural Gas Association of America (INGAA)**

*Prepared by:*

**Bruce A. Hedman  
Energy and Environmental Analysis, Inc.,  
an ICF International Company**

February 2008

# TABLE OF CONTENTS

	<b>EXECUTIVE SUMMARY</b>	<b>1</b>
<b>I.</b>	<b>INTRODUCTION</b>	<b>4</b>
<b>II.</b>	<b>BACKGROUND ON PIPELINE COMPRESSOR SYSTEMS</b>	<b>4</b>
	A. MECHANICAL DRIVES	5
	1. Reciprocating Internal Combustion Engines	6
	2. Gas Turbines	6
	3. Electric Motors	7
	B. COMPRESSOR UNITS IN SERVICE	7
<b>III.</b>	<b>APPLICATION OF WASTE HEAT RECOVERY ON NATURAL GAS PIPELINE COMPRESSOR SYSTEMS</b>	<b>8</b>
	A. HEAT RECOVERY POWER CYCLES	8
	B. OPERATING EXPERIENCE WITH COMPRESSOR WASTE HEAT RECOVERY POWER CYCLES	10
	C. BUSINESS MODELS AND PROJECT ECONOMICS: SITE SPECIFIC CONSIDERATIONS	12
	1. Business Factors	13
	2. Technical and Operational Factors	14
	3. Project Economics	15
	D. PIPELINE PROPOSAL: A PATH FORWARD	17
<b>IV.</b>	<b>APPLICATION OF TURBOEXPANDERS FOR PRESSURE LETDOWN ENERGY RECOVERY</b>	<b>20</b>
	A. ECONOMIC HURDLES TO APPLICATION OF TURBOEXPANDERS	21
<b>V.</b>	<b>APPLICATION OF TURBINE INLET AIR COOLING FOR ENERGY RECOVERY</b>	<b>24</b>
	A. EVAPORATIVE AND REFRIGERATION COOLING	25
<b>VI.</b>	<b>OVERALL CONCLUSIONS</b>	<b>27</b>
	<b>APPENDIX A: LIST OF ORGANIZATIONS INTERVIEWED</b>	<b>28</b>

# Waste Energy Recovery Opportunities for Interstate Natural Gas Pipelines

## EXECUTIVE SUMMARY

This report summarizes an analysis of three waste energy recovery opportunities applicable to the interstate natural gas pipeline system. The objective of the study is to evaluate the technical applicability of each option; identify the technical, market, and regulatory factors that affect economic viability; and gain understanding of the key technical and economic factors that make the difference between a successful and an unsuccessful energy recovery project.

Three pipeline energy recovery options are evaluated:

- Waste Heat Recovery to Power Systems on Pipeline Compressor Drives – Waste heat in the hot exhaust of a gas turbine or reciprocating internal combustion engine is recovered to generate electricity through a Rankine power cycle.<sup>1</sup>
- Turboexpanders for Pressure Letdown Recovery – Turboexpanders can be applied at city gate stations and other pressure letdown locations on the pipeline system to generate power from the reduction in gas pressure. Turboexpanders are compressors in reverse; instead of shaft power being used to compress a gas to a higher pressure, shaft power is produced by expanding a high pressure gas to a lower pressure.
- Turbine Inlet Air Cooling – Capacities of combustion turbines are rated at ambient conditions of 59°F and 60 percent relative humidity at sea level (14.7 psia). The power output and efficiency of all combustion turbines decrease with increasing ambient temperature. Turbine inlet air cooling (TIC) is used in the power industry to prevent the loss of output and efficiency of gas turbine generators during peak summer periods when ambient temperatures are high. TIC systems based on absorption chillers and driven by heat recovered in the hot exhaust of the turbine have the potential to increase compressor drive capacity and maintain turbine efficiency during periods of hot weather.

This report evaluates the current status of pipeline energy recovery projects in the United States, and identifies existing and planned projects and major project participants, including pipelines, technology suppliers, and developer/operators. Further, the report identifies key technical, economic and business factors impacting the viability of each energy recovery option through discussions and interviews with key industry participants (pipeline industry, equipment suppliers and developers), literature review, and the internal expertise of EEA staff.

This study concludes that there are applications where heat recovery to power can be and is being economically applied to the pipeline system. Turboexpanders and turbine inlet air cooling, however, do not appear to be viable commercial options for interstate natural gas pipelines under current conditions. Specific findings include:

- Waste heat recovery to power systems are economically viable in areas where power purchase prices include some incentive for clean energy (e.g., states where heat recovery qualifies as an option under a renewable portfolio standard), and where compressor

---

<sup>1</sup> The Rankine cycle is a thermodynamic cycle which converts heat into work. Central station power plants that generate electricity through a high pressure steam turbine are based on the Rankine cycle.

capacity and load factor are both above certain minimums. There are currently six operating waste heat to power projects on pipelines in North America (all based on organic Rankine cycles) with more than ten additional systems under development. Near-term applications are limited to gas turbine drives which have higher exhaust temperatures and flows and are typically larger in size than internal combustion engine drives. Project economics are affected by turbine size and load factor, and the economic feasibility of these projects can be evaluated with more certainty as a retrofit on existing compressor stations that have available operating histories. Based on current technologies and power prices, the minimum hurdles for economic waste heat recovery projects are a total station gas turbine capacity of at least 15,000 hp and stations which operate at more than 5,250 hours per year over the previous 12 months (an annual load factor at or above 60%). About 90 to 100 compressor stations in the United States meet these hurdles, representing approximately 500 to 600 MW of potential power generation capacity.

- Turboexpanders have been successfully used in LNG and natural gas processing plants for many years. Flow rates and pressure drops in these facilities are constant or predictable, and process integration allows waste heat from the process to be used for gas heating, and in many cases the cooling effect of the gas expansion can be used elsewhere in the process. There are currently no known commercial turboexpander installations generating electricity at city gates in the U.S. pipeline system. Projects have not been economically viable due to a combination of high capital cost, low purchased power prices and wide variations in flow and pressure ratio at pressure reduction stations that negatively impact turboexpander performance. The industry periodically re-evaluates the applicability of turboexpanders on the pipeline system. In fact, there are some limited demonstrations currently underway integrating fuel cells for preheating of the gas. These projects are pre-commercial demonstrations all supported by government research funds and, therefore, not a commercially viable alternative at this time.
- While turbine inlet air cooling is used in the power industry to increase power output during peak summer periods, it has not been applied to pipeline compressors in the United States because there is no parallel constraint on pipeline compressor capacity. Summer natural gas consumption is rising due to increased use of natural gas for power generation, but the delivery levels generally have not been constrained by limits on compressor capacity. Therefore, no value is placed on increasing gas turbine compressor drive output during peak summer periods. Additionally, the absorption chiller TIC system is the only approach that utilizes waste heat, but the overall efficiency benefits of applying absorption chillers to gas turbine compressor drives are negative because of the parasitic electric loads for the absorber and cooling tower equipment (the minimal improvement in fuel efficiency of the turbine is more than offset by the chiller parasitic electric loads of 0.26 to 0.28 kWh/RT).<sup>2</sup>

Although the economics of pipeline waste heat to power projects can be marginal in many applications, recent experience demonstrates that pipelines have been open to exploring waste heat to power projects as long as the third-party developers can provide assurances that their activities will not increase costs for shippers and not result in a degradation of pipeline services or equipment. As a result, compressor heat recovery projects are being developed where and when siting is feasible and there is a compelling business case for investing in such projects. These projects are being done on a retrofit basis.

---

<sup>2</sup> RT is Refrigeration Ton, 12,000 Btu/hr of cooling.

While the ability to site heat recovery for power projects and make an economic business case is affected by a variety of site-specific considerations, the primary determinant of project feasibility is the price paid for the power generated. Project margins are currently narrow and could be enhanced by a market-based approach to power purchases that recognizes the value of and rewards clean energy production such as power produced from pipeline waste heat recovery. Market deployment of compressor heat recovery to power projects would also be accelerated by providing modest incentives to the pipelines to further encourage their active participation. The Commission's affirmation that a pipeline's shareholders retain the heat revenues resulting from these non-jurisdictional power projects is one approach that would reduce current uncertainties and provide pipelines with an incentive to expend time and resources to help develop partnerships and projects.

The pipelines also recognize the need to promote increased energy efficiency and reduce green house gas (GHG) emissions. Given this, the pipelines have, though this analysis, considered ways of expediting the development process for compressor heat recovery projects. As a result of those considerations, the pipelines propose to take the following steps on a voluntary basis:

- Pipelines will identify on their websites *gas turbine* compressor stations on their systems that:
  - Have a total gas turbine station capacity of at least 15,000 hp; and
  - Operated at or more than 5,250 hours per year (60 percent load factor) over the previous 12 months.
- Pipelines that elect to outsource waste heat recovery opportunities will make specific information (detailed below) available to third-party waste heat developers about gas turbine compressor stations (including existing compressors, modifications to existing compressors, and new compressors) that meet the minimum thresholds stated above.
- Pipelines will provide this specific information to third-party waste heat developers (or an affiliate developer) upon request and subject to the developer signing a confidentiality agreement.
- Prior to entering any negotiations with a pipeline, a third-party developer may need to prove creditworthiness or supply a parent guarantee, provide evidence of appropriate insurance, and/or agree to indemnify the pipeline.
- Pipelines should have the option to develop waste heat recovery with a creditworthy waste heat developer, an affiliate, or by themselves.

The proposal presented above is a voluntary effort by the pipelines to work in partnership with third-party developers and to help facilitate development of compressor heat recovery for power projects where there is a potential for economic viability. The minimum levels for inclusion (***total gas turbine station capacity of at least 15,000 hp and station operation at or more than 5,250 hours per year over the previous 12 months***) were developed through discussions with both compressor station operators and heat recovery system developers. These levels are intended to represent a reasonable economic floor based on current technology performance and purchased power values. The specific information available to developers regarding gas turbine compressor stations that meet these minimums includes data that the developers specified as necessary to allow them to proceed with a preliminary feasibility analysis to determine if the station warrants further analysis (*Infra* at 18).

## I. INTRODUCTION

The U.S. natural gas pipeline network is a highly integrated transmission grid that delivers natural gas to and from nearly any location in the lower 48 States. The transmission grid is comprised of more than 210 natural gas pipeline systems; 300,000 miles of interstate and intrastate transmission pipeline; more than 1,400 compressor stations that maintain pressure on the network and ensure continuous forward movement of supplies; and more than 11,000 delivery points, 5,000 receipt points, and 1,400 interconnection points that provide for the transfer of natural gas throughout the United States.<sup>3</sup> The pipeline grid efficiently and safely moves approximately 20 trillion cubic feet (Tcf) of natural gas annually to residential, commercial and industrial consumers. Approximately 585 billion cubic feet (Bcf) of gas, or less than three percent of total gas consumed, is used by the compressor stations to pressurize and move the gas.<sup>4</sup>

In response to recent inquiries from FERC regarding potential energy efficiency measures in pipeline operations, the Interstate Natural Gas Association of America (INGAA) commissioned a review of the technical, regulatory, policy, and institutional status of specific energy recovery options for pipelines. This paper summarizes the results of that analysis and discusses the current status and future potential for three efficiency measures including power generation from waste heat recovered from compressor drives, turboexpander systems that generate power from the pressure reduction at pipeline city gates, and inlet air cooling technologies that are driven by waste heat recovered from reciprocating internal combustion (IC) engine or gas turbine exhaust.

## II. BACKGROUND ON INTERSTATE PIPELINE COMPRESSOR SYSTEMS

The natural gas pipeline network relies on more than 1,200 compressor stations to maintain a continuous flow of natural gas between supply areas and delivery to local distribution, municipal, industrial and electric generation customers.<sup>5</sup> Compressor stations are usually situated between 50 to 150 miles apart along the length of a pipeline system and are typically designed to operate on an unattended and non-stop basis. Most compressor stations are fueled by a portion of the natural gas flowing through the station. The average station is capable of moving about 700 million cubic feet (MMcf) of natural gas per day, while the largest can move as much as 4.6 billion cubic feet (Bcf) per day.<sup>6</sup>

Pipeline systems are often characterized in terms of “trunkline” or “grid-type” systems.<sup>7</sup> Trunkline systems are large diameter, long distance pipelines that generally link major supply areas to consuming market areas. Trunklines tend to have fewer receipt points (usually at the beginning of its route); and fewer delivery points, interconnections with other pipelines, and associated lateral lines. Grid-type systems, on the other hand, are characterized by a network of many laterals, interconnections and delivery points operating within and serving a localized

---

<sup>3</sup> Energy Information Agency, *About U.S. Natural Gas Pipelines*, 2008, [www.eia.doe.gov/pub/oil\\_gas/natural\\_gas/analysis\\_publications/ngpipeline/index.html](http://www.eia.doe.gov/pub/oil_gas/natural_gas/analysis_publications/ngpipeline/index.html)

<sup>4</sup> Energy Information Agency, *Natural Gas Consumption by End Use*, 2007, [www.tonto.eia.doe.gov/dnav/ng/ng\\_cons\\_sum\\_dcu\\_nus\\_m.htm](http://www.tonto.eia.doe.gov/dnav/ng/ng_cons_sum_dcu_nus_m.htm)

<sup>5</sup> Compressors are also used at underground natural gas storage sites for injection and withdrawal of natural gas, and in production areas where wellhead pressures are not always enough to move the flow into the high-pressure mainline or gathering header systems

<sup>6</sup> Energy Information Agency, *Natural Gas Compressor Stations on the Interstate Pipeline Network: Developments Since 1996*, November 2007.

<sup>7</sup> *Id.*

market area or region. In form, they are similar to a local distribution company (LDC) network configuration, but on a much larger scale. While there are a number of large-scale compressor stations that are associated with the major interstate trunkline systems, about three quarters of all compressor stations have an installed capacity below 20,000 hp and a throughput capacity of less than 1 Bcf per day.<sup>8</sup> This reflects the large number of grid-type pipeline systems that operate within established regional markets such as the Northeast, Midwest and Southeast. Compressor stations operating on grid-type systems tend to be designed with less horsepower than those serving trunkline systems because operational line pressure is less and average capacity is lower.

Although natural gas compressor stations vary widely in size and layout, the basic compressor systems are comprised of two components – the “mechanical drive” that provides the shaft power that drives the compressor, and the “compressor” itself. The mechanical drive can be an internal combustion (IC) engine, gas turbine, or electric motor. Electric motors, however, are not in wide use today.<sup>9</sup> The compressor can be a reciprocating, centrifugal, or screw compressor. The overall efficiency of a compressor system is the product of the mechanical drive and compressor efficiencies.

Pipeline compressor stations are designed with enough horsepower to meet firm contractual requirements. Trunkline systems often have a series of large, single-unit compressor stations along the length of the pipeline. Grid-type systems, which often have more variability in gas flow, generally have multiple compressor units in each station to provide for greater flexibility and efficiency in compression.

#### **A. MECHANICAL DRIVES**

Two types of mechanical drives are primarily in use today, IC engines and gas turbines. The majority, natural gas-fired IC engines, date back to the basic compressor station unit design originating in the first half of the 20<sup>th</sup> century. Many existing IC engine compressor systems are “integral” units, where the reciprocating engine and the compressor pistons are in the same engine block. For newer engine driven compressors, the engine and compressor are separate units that are mechanically linked together – i.e., the drive is coupled to a “separable” compressor.

The natural gas transmission industry installed most of its pipeline compression infrastructure from the 1940s through the mid-1960s. The primary requirements for these IC engines, and thus the design and operational focus, were reliability, thermal efficiency, and longevity. Gas turbine units, first introduced in compressor applications in the 1950s, have separate centrifugal compressors. Both IC engine and gas turbine units are sometimes retrofitted to include the latest technology improvements. In many instances, the objective of this revitalization is not to increase compressor capacity, but rather to increase efficiency, improve emissions and enhance safety.<sup>10</sup>

---

<sup>8</sup> Energy Information Agency, *About U.S. Natural Gas Pipelines*, 2008.

<sup>9</sup> Electric motor drives are being installed in some applications today where local environmental restrictions limit the use of IC engines or gas turbines, or in areas with low power costs.

<sup>10</sup> Energy Information Agency, *Natural Gas Compressor Stations on the Interstate Pipeline Network: Developments Since 1996*, 2007.

## 1. Reciprocating Internal Combustion Engines

IC engines are the primary compressor drive or “prime mover” used in gas transmission, with most of the units installed prior to 1970. These engines are available in a range of sizes and are central to the standard compressor station design that uses multiple engines within a compressor building. Variability in gas demand (e.g., daily, seasonal) can result in significant variation in station compression requirements – multiple IC engines allow units to be brought on-line as needed so that lower load demand can be addressed by fewer (or single) engines operating at or near full load, where thermal efficiency is highest. This provides a much more cost-effective and efficient approach to managing station demand than running large units at reduced load. In addition, IC engines perform more efficiently at reduced load and are more responsive to load changes than gas turbines.

There are many different engine makes, models and designs within the existing pipeline infrastructure. However, the IC engine population remains predominantly large cylinder bore (14 – 18 inch diameter), slow speed (250 – 400 rpm) “integral” engines, such as Cooper, Clark, Ingersoll Rand, and Worthington engines driving an integral reciprocating compressor. These engines, which were specifically built for gas transmission, are no longer manufactured. Newer generation IC engines are higher speed (800 – 1100 rpm) four-stroke cycle engine units, such as Caterpillar, Waukesha, or White Superior engines. The high speed units are linked to a separable compressor – typically a reciprocating compressor.<sup>11</sup> Reciprocating compressors are the predominant choice for IC engine compressor drives.

IC engines include 2-stroke cycle lean-burn, 4-stroke lean-burn, and 4-stroke rich-burn designs. Based on the INGAA database of pipeline compressor units, approximately 75 percent of the installed IC engines are lean-burn and most of these lean-burn engines are 2-stroke cycle. Lean-burn engines have lower characteristic exhaust temperatures than rich-burn engines (700 to 850°F versus 900 to 1200°F respectively), and exhaust from a 2-stroke lean-burn engine is cooler than from a 4-stroke lean-burn engine (500 to 700°F versus 700 to 850°F respectively).<sup>12</sup> The exhaust temperature differences, which would impact waste heat recovery, are primarily due to relative differences in the amount of combustion air. It is also important to note that only about 40 percent of the heat or energy loss from an IC engine is contained in the hot exhaust gases. Most of the heat is removed at very low temperatures (below 150°F) through jacket cooling water. ***This means that only a portion of IC engine waste heat (the portion that is in the exhaust) can be effectively recovered for power generation applications.***

## 2. Gas Turbines

Gas turbines, or combustion turbines, are *continuous* internal combustion engines and their use as drives for centrifugal compressors on natural gas transmission pipelines has become more prevalent in recent years. Ideally, gas turbines are used where higher load demand is expected so that the unit(s) can operate at or near full load conditions to avoid greater inefficiencies at part load compared to IC engines. Typical capacities of pipeline gas turbines range from 1,500 to over 35,000 hp. ***Gas turbines have relatively high exhaust temperatures (850 to 1100°F) which make them more suited for heat recovery applications. Additionally, in contrast to***

---

<sup>11</sup> Centrifugal compressors can also be used, but a reciprocating engine / centrifugal compressor pairing has poor load response and higher efficiency losses through the gear box.

<sup>12</sup> Innovative Environmental Solutions, Inc., *High Efficiency Natural Gas Compressor Drivers: Technology Status, Market Barriers and Future Development for Increased Compressor Efficiency*, Draft report to INGAA, December 2006.



**reciprocating IC engines, almost all of the energy losses in a gas turbine are contained in the hot exhaust gases.** Primary gas turbine manufacturers supplying pipeline applications include Solar Turbines, General Electric and Rolls Royce.

Some gas turbine engines used in natural gas transmission compression applications employ a regenerator to use exhaust gas to pre-heat the combustion air. These units have a significantly lower exhaust gas outlet temperature than simple cycle gas turbines and are not generally suited for waste heat recovery applications.

### **3. Electric Motors**

Electric motor drives are being considered more frequently by pipeline companies where local environmental restrictions limit the use of IC engines or gas turbines, where companies value the low maintenance costs of electric motor drives, or in areas with low power costs. Historically, electric motor drives have not been used extensively due to concerns about reliability in severe weather and the fuel cost advantages of natural gas powered IC engines and turbines. The reliability issue is a paramount concern to pipeline operators. Natural gas serves as the primary energy source to drive the pipeline system; with purchased electricity, operators no longer control the energy source and are subject to disruptions in electrical power. Electric motor/compressor combinations are relatively efficient at the point of use (i.e., not including the efficiency of generating the electricity). Large electric motors generally have high efficiencies, typically greater than 95% over an operating range of 50-100 percent of rated load. Electric motors can be paired with centrifugal or reciprocating compressors.

## **B. COMPRESSION UNITS IN SERVICE**

INGAA maintains a database of pipeline compressor units that includes the vast majority of units in interstate gas transmission service, and some units in intrastate service. The current version is updated through 2004.

- There are approximately 5,400 reciprocating IC engines operating in U.S. compressor stations in the database. The rated horsepower of IC engines in natural gas transmission service varies considerably, with an average size of about 1,700 hp. Most IC engines (60 percent) fall into the range of 1,000 to 3,500 hp, with about nine percent of the population larger than 3,500 hp.
- The database includes over 1,000 gas turbines at 473 U.S. compressor stations representing almost 7 million hp of total capacity. These industrial scale turbines have an average capacity of about 6,600 hp (5.0 MW). Over 50 percent of the gas turbine drives are less than 5,000 hp in size. A little over nine percent of compressor gas turbines are greater than 15,000 hp in size; these units, however, represent over 25 percent of total gas turbine capacity.
- Most of the IC engines (about 2/3) are integral engines, specifically designed for pipeline use.
- About 50 percent of the IC engines have been in service for more than 45 years. Two-thirds were installed before 1970, and about 12 percent were installed after 1990.
- The electric motor-driven compressor population is small but growing in some locations as permitting combustion systems is becoming more problematic due to air quality concerns.

Electric motor-driver compressors are also installed in remote locations where remote start reliability is a critical design factor.

### III. APPLICATION OF WASTE HEAT RECOVERY ON NATURAL GAS PIPELINE COMPRESSOR DRIVES

Natural gas fueled engines and turbines (mechanical drives) generate heat as a byproduct. Only about one third of the fuel energy consumed by an engine or turbine ends up as useful mechanical power, the remaining two-thirds are rejected as hot exhaust or in engine cooling systems. In industrial or commercial combined heat and power (CHP) applications, this heat is recovered and used to provide hot water or steam for the site, dramatically improving the overall fuel use efficiency of the system. **CHP is difficult to implement at pipeline compressor stations because there are very few thermal energy requirements at compressor stations, and compressor stations, in general, tend to be located in isolated locations which precludes providing the steam or hot water to an adjacent industrial or commercial user.**

#### A. HEAT RECOVERY POWER CYCLES

An alternative to recovering heat to provide thermal energy is to recover the energy in the hot exhaust to generate mechanical power or electricity through a Rankine power cycle as shown in **Figure 1**. Power produced by such a heat recovery system could be used internally at the site, or more likely in pipeline compressor applications, sold into the electric grid.

**Figure 1. Waste Heat Recovery Power Cycle**

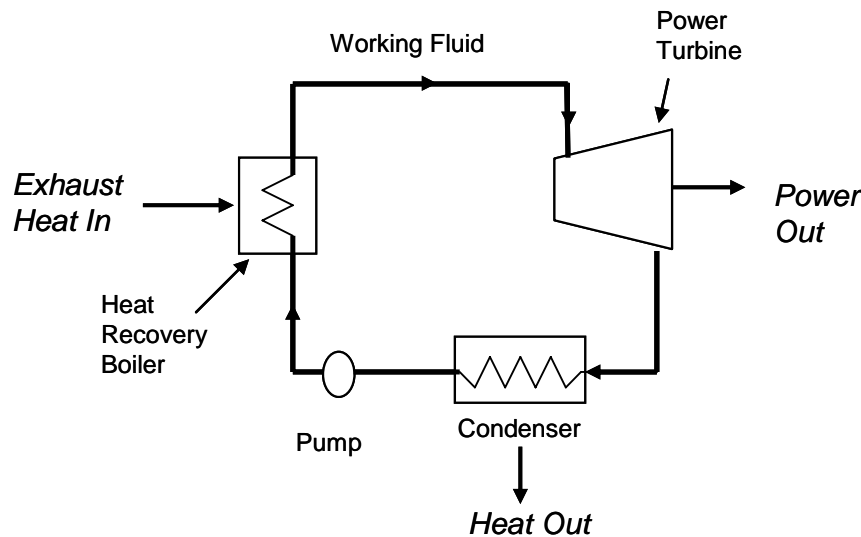

In a heat recovery Rankine cycle, a working fluid is first pumped to elevated pressure before entering a heat recovery boiler. The pressurized fluid is vaporized by the hot exhaust, and then expanded to lower pressure in a turbine, generating mechanical power that can drive an electric generator. The low pressure vapor is then exhausted to a condenser at vacuum conditions where heat is removed condensing the vapor back into a liquid. The condensate from the condenser is then returned to the pump for continuation of the cycle. This is the same cycle used in a conventional power plant, except that in that case the working fluid is steam and the

boiler is directly fired. Steam is also used in heat recovery cycles, but the lower temperatures typically found in heat recovery applications allow other working fluids to be used as well. A system that uses a hydrocarbon as the working fluid is referred to as an organic Rankine cycle (ORC). ORCs are based on the cycle outlined in **Figure 1** and include similar but slightly different components including a vaporizer, preheater, condenser and recuperator.

There are numerous examples of both steam cycles and ORCs being used to generate power from waste heat or from low to medium temperature energy sources. Steam cycles are often used in industrial applications to generate power from operations with hot exhaust gases such as coke oven batteries and cement kilns. ORCs are commonly used to generate power in geothermal power plants, and more recently, in compressor heat recovery applications. In fact, all compressor heat recovery projects to date are based on ORC systems.

Suppliers of ORC systems claim several advantages over conventional steam plants for “low- to mid-temperature” compressor station applications:

- Economy of size; Hydrocarbon working fluids have lower specific volumes than steam resulting in smaller, more compact equipment.
- Hydrocarbons condense at higher pressures than steam given a constant temperature, reducing turbine size requirements and air-in leakage potential.
- ORC condensers are typically air-cooled rather than water-cooled. This enhances applicability in remote locations where water supplies may not be readily available and eliminates disposal issues for cooling-water treatment chemicals.
- Hydrocarbons have lower freezing points than water, eliminating condenser freeze-up concerns and allowing the condenser to transfer heat at a lower temperature, increasing cold weather performance.
- Hydrocarbons such as pentane remain dry during turbine expansion while steam can form moisture droplets that cause erosion damage during high-speed collisions with turbine components.
- Under current regulations in most states, ORC systems do not require a licensed steam plant operator for continuous (24/7) monitoring and thus can operate in remote, unmanned locations.

In contrast to ORC systems, steam cycles can take better advantage of the higher exhaust temperatures of some gas turbines, and can generate more power than ORCs with slightly lower capital costs. However, most states currently require the presence of licensed operators on a continuous basis for steam systems, increasing operating costs significantly. For this reason, compressor waste heat projects to date have used ORC systems.

The amount of energy that can be recovered by any power cycle from the exhaust of an engine or gas turbine is a function of the temperature and volume of the exhaust gases. ***Gas turbines appear to offer the most potential for viable heat recovery projects under current conditions.*** In addition to having the majority of their heat rejected in low temperature engine cooling systems, IC engines operate close to stoichiometric combustion conditions resulting in lower exhaust flows due to less inlet air volumes. Gas turbines, on the other hand, reject almost all of their heat in the hot exhaust gases and operate with 200 to 300 percent excess air,

resulting in both higher exhaust temperatures and greater exhaust flow rates per horsepower output. ***Coupled with the fact that IC engine drives are typically smaller than gas turbine compressor drives and are often grouped together in multiple units at stations that have widely fluctuating demand, IC engines do not appear to be viable near-term applications for exhaust heat recovery.*** As shown in the next section, all existing compressor power recovery systems in North America have been applied to gas turbine drives.

## B. OPERATING EXPERIENCE WITH COMPRESSOR WASTE HEAT RECOVERY POWER CYCLES

A number of companies have been actively pursuing compressor heat recovery projects in North America over the past several years. Recycled Energy Development in Westmont, Illinois designs, builds and operates heat recovery power projects, but to date has no systems installed on pipeline compressors. Ormat Technologies in Reno, Nevada has supplied ORCs to geothermal applications for close to twenty years and currently has six compressor recovery systems and one natural gas processing plant system in operation in the U.S. and Canada (**Table 1**). In addition, there are at least ten additional systems in the construction or planning stages (**Table 2**). Other companies including Ridgewood Renewable Power, TAS, and WOW Technologies are actively pursuing this market with ORC technologies but have no existing compressor installations.

**Table 1. Ormat ORC Systems Applied to Gas Turbine Drives – Existing Systems**

Project	Gas Turbine	Turbine Horsepower	Recovered Power	Power Purchaser	Year
TransCanada Pipeline, Gold Creek Station, Alberta, Canada	Rolls Royce, RB211	38,000 hp	6.5 MW	Alberta Power Pool	1999
Neptune Gas Processing, Centerville, Louisiana	Solar Mars 100 (2)	12,000 hp (each)	4.6 MW	Internal Use	2004
Northern Border Pipeline, St. Anthony, North Dakota	Rolls Royce, RB211	38,000 hp	5.5 MW	Basin Electric Cooperative	2005
Northern Border Pipeline, Wetonka, South Dakota	Rolls Royce, RB211	38,000 hp	5.5 MW	Basin Electric Cooperative	2006
Northern Border Pipeline, Clark, South Dakota	Rolls Royce, RB211	38,000 hp	5.5 MW	Basin Electric Cooperative	2006
Northern Border Pipeline, Estelline, South Dakota	Rolls Royce, RB211	38,000 hp	5.5 MW	Basin Electric Cooperative	2006
Alliance Pipeline, Kerrobert Station, Saskatchewan, Canada	GE LM2500	33,000 hp	5.5 MW	SaskPower	2006

**Table 2. Ormat ORC Systems Applied to Gas Turbine Drives – Planned Systems<sup>13</sup>**

Project	Gas Turbine	Turbine Horsepower	Recovered Power	Power Purchaser	Developer
Alliance Pipeline, Saskatchewan, Canada (3 additional stations)	GE LM2500	33,000 hp	6.5 MW	SaskPower	NRGreen
Spectra Energy, British Columbia, Canada (5 stations)	GE LM2000/ GE LM2500	28,000 hp	5.0 MW	BC Hydro	EnPower
Trailblazer Pipeline, Peetz Station, Colorado	Solar Mars 100 (2)	10,000 hp* (each)	4.0 MW	Highline Electric Cooperative	Ormat
Northern Natural Gas, Earlville Station, Iowa	Solar Mars 100	13,000 hp	3.0 MW	Local Electric Cooperative	Ormat

\*Turbine capacity is derated due to the effects of high altitude

**Figure 2** shows the ORC heat recovery unit as installed at Northern Border Pipeline's St. Anthony compressor station in North Dakota. The figure illustrates the placement of the heat recovery system, including the heat recovery unit and stack and the air-cooled condenser unit, in relation to the existing compressor station facilities.

**Figure 2. Organic Rankine Cycle Heat Recovery Power Generation at Compressor Station No. 7, Northern Border Pipeline Co.**

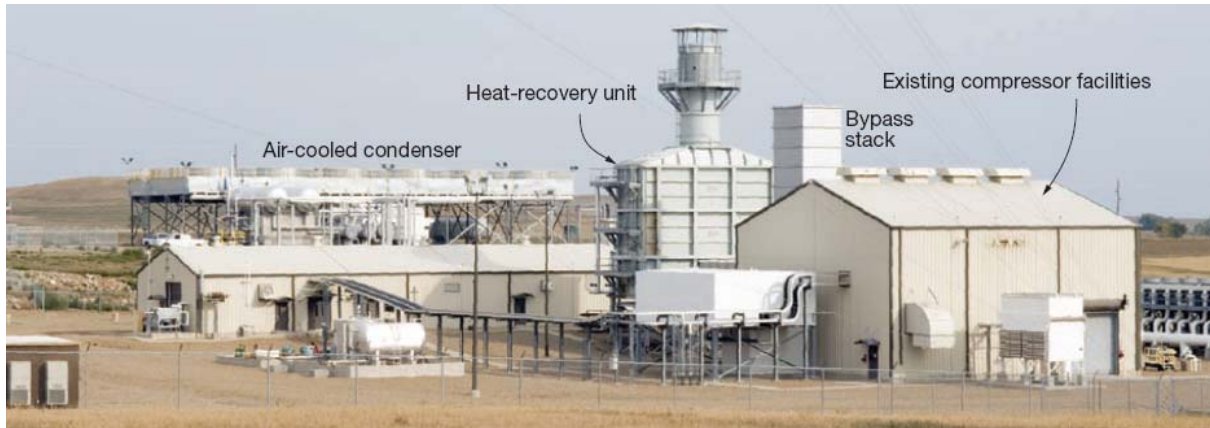

Source: Ormat Technologies

The Ormat ORC uses pentane as the working fluid, and utilizes a heat transfer fluid in the heat recovery unit to transfer the heat in the gas turbine exhaust to the pentane working fluid. Discussions with Ormat and pipeline personnel indicate that the operating experience of the existing compressor recovery projects has been for the most part positive. The initial system installed in 1999 at Gold Creek station on TransCanada pipeline did experience some start-up

<sup>13</sup> This table only identifies publicly-announced projects. There are additional projects in the negotiation process.

problems, partly because this system was an early prototype and used steam as the heat transfer medium to the pentane instead of thermal oil.

The overall impact to compressor station operations by the installation of the heat recovery systems appears to have been minimal in these cases. The only operational impact during installation of the heat recovery system is the addition of a bypass valve to the existing turbine exhaust ducts. The installation of this valve does require a short shutdown, but this is the extent of interruptions to compressor operation by the integration of the heat recovery system. The heat recovery units themselves are generally housed within the confines of the compressor stations but in separate fenced-in areas with separate access that provides a clear delineation of ownership and operations.

The installations also had minimal impact on site permits of the presently sited units. While the additional equipment requires a larger footprint than the existing station and affects the visual landscape, the ORCs have been guaranteed to remain within permitted noise limits of affected populations. Depending on local requirements, modifications are sometimes needed to existing air permits (the lower temperature exhaust from the ORC recovery unit may require new dispersion analysis in some cases), but these modifications have been relatively minor and easily granted. The developer has provided the additional modeling and analysis when required, and covered repermitting costs.

Similarly, there has been no discernable impact from increased back pressure on turbine operations from these installed units. It appears that many contracts include a provision for the developer to cover any increased turbine fuel costs in case turbine efficiency is affected, but there have been no impacts to date.

The pipeline companies have no operating responsibility for the heat recovery power systems in any of the existing installations. The systems are typically operated remotely, and the responsible developer provides major maintenance support in all cases. Day to day maintenance tasks of the heat recovery systems have been contracted out to the pipeline maintenance staff in several of the installations.

### **C. BUSINESS MODELS AND PROJECT ECONOMICS: SITE SPECIFIC CONSIDERATIONS**

The current model for pipeline compressor waste heat electric generation projects in the United States is that such projects are developed by third-party developers (Ormat has been the developer/owner/operator on five of the existing installations. Other third-party developers including an unregulated pipeline affiliate of Alliance pipeline, NRGreen, have been the owner/operator on the other installations). The third-party developer owns and operates the waste heat recovery equipment, has a long-term power purchase contract with a local utility or power wholesaler, and pays the compressor station owner/operator for the waste heat and land use. Such arrangements are not surprising given that third-party developers are most likely in the best position to evaluate the commercial feasibility of a compressor waste heat power generation project. It is the core business of third-party project developers and they have the expertise and experience to make informed evaluations.

It is important to highlight the variety of site-specific considerations that affect both the ability to site compressor heat recovery systems and the business case for investing in such systems. These considerations include technical and operational factors (such as size of the compressor drive and the number of units), geographic considerations (such as ambient conditions, value of

electricity in the regional power market, access to transmission lines), regulatory issues (such as environmental permitting and whether waste heat generation qualifies as renewable power) and contractual and financial thresholds (such as the availability of purchased power contracts and return on investment thresholds). ***In the end, only a limited number of compressor locations will be suitable for producing electricity from waste heat.***

## 1. Business Factors

There are a number of project-specific business and contractual issues that impact project economics. Key factors include:

- Heat is provided on an as-available basis – Understandably, there is no requirement to operate the compressor drives if they are not required by the normal operation of the compressor station. This places all of the operating risk on the third-party owner/operator. This also may reduce the value of the power to potential purchasers.
- Power purchase contracts – Long term power purchase agreements (20 to 30 years) seem to be typical for the existing projects. The prices paid for power appear to be in the \$0.035 to \$0.05/kWh range.
- “Green Power” value has driven most existing projects – Most of the installations have been in states or provinces where waste heat recovery qualifies for some level of incentive in existing renewable portfolio standards (RPS) or where waste heat to power is a qualified green power resource. RPS programs require utilities to generate or purchase a certain percentage of their electricity from renewable energy sources or recovered heat sources.<sup>14</sup> Utilities can acquire tradable credits or renewable energy certificates (RECs), also known as Green Tags, for qualified green power supplies. For example, the power purchased by Sask Power from the Alliance pipeline installations qualifies under the “Environmentally Preferred Power” program; Basin Electric Cooperative retained green credits as part of the power purchase agreement (PPA) for the Northern Border Pipeline installations; the Spectra Energy systems in British Columbia will have a long term PPA with BC Hydro as part of BC Hydro’s “Clean Energy Program”; and the planned Trailblazer system will generate Green Credits as qualified under the recently enacted Colorado RPS. Compressor heat recovery power generation is particularly attractive because it generates power with no additional fuel consumption and with no additional emissions of greenhouse gases (GHG). RPS or Green Credit qualifications currently add about \$0.005 to \$0.01/kWh to the value of the power produced.
- Without the “Green Power” driver, power purchase agreements have been difficult to negotiate and the value of purchased power is reduced.
- Payments to pipelines – Based on existing projects, pipelines are typically compensated for the heat based on kWh produced, with some guaranteed minimum. Payments are estimated to be around \$0.005/kWh which would equal approximately \$165,000 per year for a 5 MW system operating at a 75 percent load factor. Minimum guarantees appear to be on

---

<sup>14</sup> While over 30 states have enacted some form of RPS in the United States, CHP is included as a qualified option in only ten state RPS programs. Five states specifically include waste heat recovery systems (North Dakota, Nevada, Arizona, Colorado, and North Carolina (effective 2012)) as part of their RPS programs.

the order of \$50,000 to \$65,000 per year.

## 2. Technical and Operational Factors

In addition to the impacts of basic capital/construction and operating costs on project economics and the effect of the specific project business factors discussed above, the economic viability of pipeline compressor heat recovery depends on a number of site-specific technical and operational parameters. These include:

- Compressor drive capacity - Due to economies of scale, the single gas turbine drive, or the total of multiple smaller turbine drives, must be of at least a certain size to generate a minimum required amount of waste heat (gas flow and temperature). While the presence of multiple small drivers lessens the economic viability of a project, evidence from existing and planned systems suggests that a minimum gas turbine(s) capacity of 15,000 hp is needed to economically apply waste heat power recovery at this point in time.
- Plant configuration - The plant must have sufficient land to locate the waste heat recovery and power equipment including the heat recovery unit(s) and the air cooled condenser. Space near and access to the gas turbine exhaust(s) are needed for efficient and cost-effective heat recovery.
- Load factor and operating load profile - Seasonal and daily demand fluctuations are typical for many pipelines. The amount of power that can be produced by a gas turbine heat recovery system is proportional to the compressor load profile. Compressors that operate at or near full load for extended annual hours (i.e., have a high load factor) are much better candidates for heat recovery application than compressors with highly variable loads. In addition to producing more power, compressors with a high load factor will provide a steady, predictable power supply that is more valuable to purchasers. Discussions with developers and pipeline personnel suggest that a minimum load factor of 60 percent is needed to apply waste heat power recovery economically.
- Ambient conditions -The ambient temperature and pressure (altitude) impact the efficiencies and outputs of both the gas turbine and the power recovery cycles. High temperatures reduce the power output of both the gas turbine and the heat recovery system.
- Location/Proximity of the grid connection - The distance from the compressor station to the power grid will impact interconnection costs, particularly if the operator must install transmission lines and ancillary equipment (e.g., transformers). These costs can be significant and can impact project economics.
- Retrofit versus new compressor station - The economic feasibility of a waste heat project depends heavily on the amount of heat available for electric generation. As a practical matter, this is a product of both the compressor turbine's ability to produce waste heat (exhaust temperature and flow) and the amount of time that the compressor actually operates. ***The economic feasibility of waste heat power generation can be evaluated with more certainty as a retrofit project based on the availability of operating history of the compressor engine or station.*** While a pipeline may be designed based on assumptions about flows, the actual flow of gas and the resulting utilization of compressor engines are driven by the extent to which customers actually utilize their contracted capacity and the patterns of such usage. In addition, it often takes time for a new pipeline to "ramp up" its load factor (e.g., the rate at which natural gas supply enters production) to the point



at which there is sufficient operating history to make an informed analysis about the feasibility of waste heat power recovery.

### 3. Project Economics

Given the range in power purchase values of \$0.035 to \$0.05/kWh and the many site-specific factors that potentially affect capital and operating costs, the economic margins for compressor heat recovery appear to be quite narrow. The following discussion estimates the costs to produce power on a \$/kWh basis based on publicly available capital and operating cost data for gas turbine waste heat recovery ORC power systems, including the following estimates for capital and O&M costs:

- Total installed capital costs are estimated to be in the range of \$2,000 to \$2,500/kW. For a 5 MW system, the capital costs would be \$10 – \$12.5 million. Total installed capital costs include equipment, installation and grid interconnection costs.
- Operating and maintenance (O&M) cost estimates range from \$0.001 to \$0.005/kWh. Unlike steam-driven systems, ORC systems do not require a licensed steam plant operator for continuous monitoring and are thus likely to have lower operating costs than steam cycles.

As shown in **Table 3**, the total costs to generate power for a typical ORC compressor heat recovery system with equipment life of 20 years, load factor of 95 percent and cost of capital of 8 percent assuming 100 percent financing are on the order of \$0.035 to \$0.040/kWh.

**Table 3. Cost to Generate Power**

Operating Costs	
Fuel Costs, \$/kWh	\$0.000
Heat Costs, \$/kWh	\$0.005
O&M Costs, \$/kWh	\$0.002
<i>Operating Costs to Generate Power, \$/kWh</i>	<i>\$0.007</i>
Capital Costs	
Installed Cost, \$/kW	\$2,500
Load Factor, %	95%
Annual Operating Hours	8,322
Equipment Life, years	20
Cost of Capital, %	8%
<i>Capital Charge, \$/kWh</i>	<i>\$0.0306<sup>15</sup></i>
<i>Total Cost to Generate Power, \$/kWh</i>	<i>\$0.0376</i>

<sup>15</sup> For comparison, the capital charge based on a 10 year equipment life and 8% cost of capital would be \$0.045/kWh

As indicated earlier, current power purchase prices for existing compressor heat recovery projects are in the range of \$0.035 to \$0.05/kWh. At \$2,500/kW capital cost and 95% load factor, a power price of \$0.05/kWh provides a simple payback of seven years. By comparison, a power price of \$0.035/kWh provides a simple payback of ten years. A recently released report from DOE on the cost and operation of the ORC system on the Northern Border Pipeline compressor station in North Dakota concluded that projects would require a minimum purchase price of \$0.05/kWh for an acceptable return on investment.<sup>16</sup>

The costs to generate power from the heat recovery system are strongly affected by capital cost and annual operating hours or load factor. **Figure 3** shows that the estimated cost to generate power exceeds \$0.05/kWh for capital costs of \$3,500/kW or higher (assuming a 95% load factor). This indicates that systems with capital costs greater than \$3,500/kW are not economically viable in today's environment because the cost to generate power exceeds the prices currently being paid for that power.

**Figure 3. The Cost to Generate Power as a Function of Capital Cost in \$/kW**

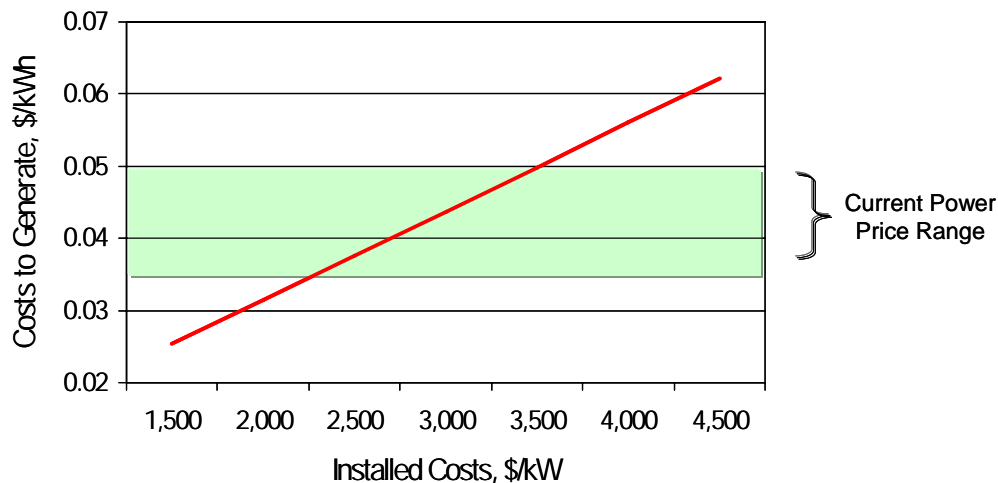

**Figure 4** shows that the cost to generate is above \$0.05/kWh for annual operating hours below 6,000, or below a load factor of 68 percent (for a system with \$2,500/kW capital costs). This indicates that systems with less than 6,000 annual operating hours are not economically viable in today's environment because the cost to generate power exceeds the prices currently being paid for that power.

<sup>16</sup> *Final Report for the Basin Electric Project at Northern Border Pipeline Company's Compressor Station #7, Oak Ridge National Laboratory, ORNL/TM-2007/158*

**Figure 4. The Cost to Generate Power as a Function of Compressor Operating Hours**

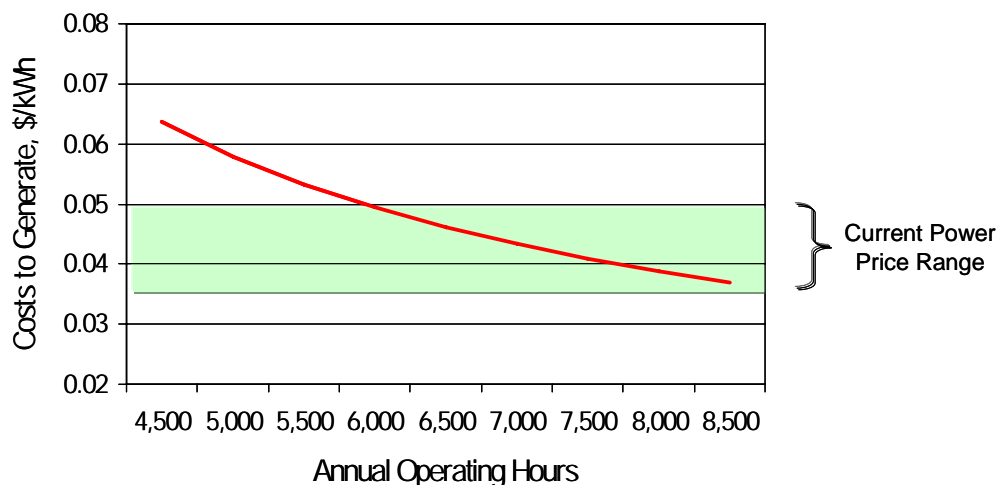

#### **D. PIPELINE PROPOSAL: A PATH FORWARD**

While the economics for pipeline waste heat to power projects are marginal in many applications, recent experience has shown that pipelines have been open to exploring whether a mutually beneficial partnership can be developed to sell compressor engine waste heat as long as the third-party developers can provide assurances that their activities will not increase costs for shippers or result in a degradation of pipeline services or equipment. As a result, compressor heat recovery projects are being developed where and when siting is feasible and there is a compelling business case for investing in such projects.

While the ability to site heat recovery for power projects and to make the business case is affected by a variety of site-specific considerations, the primary determinant of project feasibility is the price paid for the power generated. ***Project margins are currently narrow and could be enhanced by a market-based approach to power purchases that recognizes the value of and rewards clean energy production such as power produced from pipeline heat recovery.*** Some form of incentive payment for Green House Gas (GHG) reductions may be an effective way of promoting the further development of compressor heat recovery projects.

Market deployment of compressor heat recovery projects would also be accelerated by providing modest incentives to the pipelines to further encourage their active participation. ***The Commission's affirmation that a pipeline's shareholders retain the heat revenues resulting from these non-jurisdictional power projects is one approach that would reduce current uncertainties and provide pipelines with an incentive to expend time and resources to help develop partnerships and projects.***

The pipelines also recognize the need to promote increased energy efficiency and reduce GHG emissions. Given this, the pipelines have, through this analysis, considered ways of expediting the development process for compressor heat recovery projects. As a result of those considerations, the pipelines propose to take the following steps:

- Pipelines will identify on their websites *gas turbine* compressor stations on their systems that:
  - Have a total gas turbine station capacity of at least 15,000 hp; and
  - Operated at or more than 5,250 hours per year (60 percent load factor) over the previous 12 months.
- Pipelines that elect to outsource waste heat recovery opportunities will make specific information (detailed below) available to third-party waste heat developers about gas turbine compressor stations (including existing compressors, modifications to existing compressors, and new compressors) that meet the minimum thresholds stated above.
- Pipelines should be exempt from providing information for qualifying sites that already have operating waste heat recovery facilities or are in the process of being developed for waste heat recovery.
- Pipelines will provide this specific information to third-party waste heat developers (or an affiliate developer) upon request and subject to the developer signing a confidentiality agreement.
- Prior to entering any negotiations with a pipeline, a third-party developer may need to prove creditworthiness or supply a parent guarantee, provide evidence of appropriate insurance, and/or agree to indemnify the pipeline.
- Pipelines should have the option to develop waste heat recovery with a creditworthy waste heat developer, an affiliate, or by themselves.

The data that pipelines will provide to third-party developers that submit confidentiality agreements for each station that passes the minimum hurdles as stated above will include:

- Gas turbine makes and models (e.g., Solar Mars 100);
- Station longitude and latitude;
- Servicing electric utility;
- Line voltage on the grid side of station transformer; and
- Hourly operating profile over a 12-month period:
  - For new/planned stations, a pipeline will only be able to provide estimated capacity factor; and
  - For existing compression units, a pipeline cannot guarantee and will not warrant that the past 12 months of operating experience is indicative of future operating periods, because many factors outside a pipeline's control can affect its operating profile, such as weather, customer usage patterns, etc.

In addition, the pipelines seek certain clarifications from FERC to further expedite project implementation:

- Expressly exclude waste heat pipeline affiliates from the definition of the term “Marketing Affiliate” under the Commission’s regulations;
- Confirm that gas turbine compressor exhaust, a waste product, is owned by the pipeline and not subject to recompense for the shippers’ account;
- Allow pipelines to retain ownership of any offsets that might be created under climate change legislation and the Commission should refrain from any action that could cause waste heat recovery to be ineligible for offsets; and
- Confirm that waste heat power generation assets and business are non-jurisdictional for ratemaking and certificate purposes.<sup>17</sup>

Finally, pipelines agree to work with project developers to include minimum design accommodations in new station plans in order to promote heat recovery implementation. Specifically:

- Pipelines commit to working with developers on a voluntary basis regarding planned compressor stations that meet the minimal hurdles to:
  - Ensure access and space around turbine exhausts; and
  - Locate cable trays and other systems to allow better access in exhaust area.
- Developers may, at their election, pay for an option for additional acreage for future heat recovery siting. The pipeline will not be obligated to make available acreage on which it has acquired an option for its own possible expansion.

The proposal presented above is a voluntary effort by the pipelines to work in partnership with third-party developers and to help facilitate development of compressor heat recovery for power projects where there is a potential for economic viability. ***The minimum levels for inclusion (total gas turbine station capacity of at least 15,000 hp and station operation at or more than 5,250 hours per year over the previous 12 months) were developed through discussions with both compressor station operators and heat recovery system developers.*** These levels are intended to represent a reasonable economic floor based on current technology performance and purchased power values. ***The information that will be provided for stations that meet these minimums is the data that the developers specified as necessary to allow them to proceed with a preliminary feasibility analysis to determine if the station warrants further analysis.*** This information should be available for most compressor stations and can be gathered and processed with reasonable internal efforts.

---

<sup>17</sup> See, e.g., *Ormat Inc.*, 64 FERC ¶ 61,036 (1993).

#### IV. APPLICATION OF TURBOEXPANDERS FOR PRESSURE LETDOWN ENERGY RECOVERY

A turboexpander is essentially a compressor in reverse. Instead of shaft power being used to compress gas to a higher pressure, shaft power is produced by expanding gas to a lower pressure. Expanders are commonly used in air separation, LNG and hydrocarbon processing applications where steady pressure ratios and flows, and high load factors are common. Turboexpanders are available in sizes ranging from 1 to 15,000 hp. It is common practice in the natural gas industry to utilize pressure regulating valves to reduce high pressure gas in the interstate pipeline system to lower distribution pressures for customer delivery. The industry has periodically evaluated the viability of using turboexpanders to recover useful energy from the pressure drop in the form of shaft horsepower which could generate electricity for internal use or for sale to the electric grid. ***There are currently no known commercial turboexpander installations generating electricity at city gates in the U.S. pipeline system. Projects have not been economically viable due to a combination of high capital cost, low purchased power prices and wide variations in flow and pressure ratio at pressure reduction stations affecting turboexpander performance.***

The basic components of a turboexpander generating system installed in parallel to a pressure reducing regulator valve are shown in **Figure 4**.

**Figure 4. Components of a Turboexpander System**

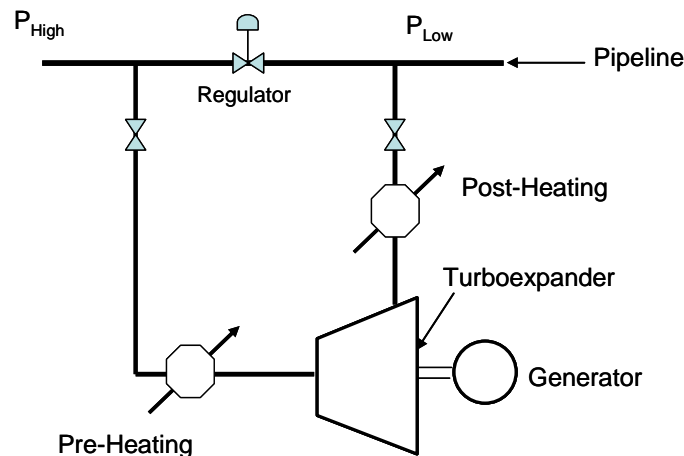

Expansion through the turboexpander is ideally an isentropic process as opposed to throttling gas through a regulator which is ideally an isenthalpic process<sup>18</sup>. In an isenthalpic throttling, there is a temperature decrease in the gas due to the Joule-Thomson effect, but there is no change in the enthalpy of the gas as it is reduced in pressure. In an isentropic expansion, the enthalpy of the gas also decreases as the gas is expanded. This change in enthalpy releases energy that is converted to power. The extraction of energy from the gas results in a greater temperature reduction for an isentropic expansion compared to an isenthalpic throttling over the same pressure ratio. For natural gas pipeline applications where certain minimum temperatures

<sup>18</sup> In an isenthalpic expansion there is no transfer of heat to (or from) the surroundings, and no work done on (or by) the surroundings. In an isentropic or constant entropy expansion, work is extracted during the expansion, removing energy from the gas and resulting in a lower temperature of the expanded gas.

must be maintained to prevent condensation or hydrate formation, the greater temperature drop of an isentropic power expansion can be a critical consideration. As a result, as shown in **Figure 4** most applications of turboexpanders will require either pre- or post-heating of the gas in order to ensure it remains above minimum temperature levels.

Turboexpanders offer great promise from an energy efficiency perspective in that they have the potential to provide power at very high efficiency (low heat rates). Even while including the substantial heating of the gas required to maintain minimum temperatures, typical heat rates for power generated through a turboexpander on a natural gas pipeline city gate would be in the 3,000 to 5,000 Btu/kWh range, compared to close to 10,000 Btu/kWh for conventional power plants. This heat rate can be further reduced if the heating can be provided by a source of waste heat from another process or application.

Despite obvious benefits in applying turboexpanders to the natural gas pipeline system, the actual use in the United States has been minimal. While extensively used in air separation plants, LNG and hydrocarbon processing facilities, there are currently no known commercial turboexpander installations generating electricity at city gates in the U.S. pipeline system.<sup>19</sup> The gas industry has periodically looked at utilizing turboexpanders since the 1970s.<sup>20</sup> A limited number were installed in the 1980s as demonstration systems (see **Table 3**), but it appears all these were subsequently shut down.

**Table 3. Installations of Turboexpanders in Natural Gas Pipelines<sup>21</sup>**

Location	Application	Size, Hp, (kW)	Design Flow and Pressure Drop	Year Installed
San Diego, CA (SDG&E)	City Gate	365 (260)	11 MMCF/D (810 – 390 psia)	1983
Memphis, TN (Memphic Light)	Chemical Plant	600 (450)	15 MMCF/D (450 – 87 psia)	1983
Stockbridge, GA (Transco Pipeline)	Compressor Station	400 (300)	7 MMCF/D (555 – 85 psia)	1984
Hamilton, NJ (Starmark Energy)	City Gate	3,862 (2,800)	36 MMCF/D (635 – 70 psia)	1987

#### **A. ECONOMIC HURDLES TO APPLICATION OF TURBOEXPANDERS**

Discussions with pipeline personnel and developers that have tried to promote this market identified a number of key hurdles to economic application of turboexpanders to pipelines. A variety of site specific factors affect project economics, the most important of which are the high capital cost of the systems themselves, and the recoverable value of the electricity generated. Other key variables include the gas flowrate and pressure drop, which together determine the power generation potential, and the hourly, daily and seasonal variability in flow.

<sup>19</sup> There may be as many as 20 turboexpander systems in commercial operation in Europe – “Enbridge Pipeline Ultra-Clean Power Generation Project” presentation by Stephen Pogorski, Enbridge Gas, 46<sup>th</sup> Annual CGA Gas Measurement School, June 6, 2007.

<sup>20</sup> *Energy Recovery in Natural Gas Depressurization Stations*, Engineering Report, GRI-79/0107.

<sup>21</sup> *Application of Turboexpanders for Pressure Letdown Energy Recovery*, Engineering Technical Note, Operating and Engineering Services Group, American Gas Association, 1987.

- **Capital Costs** – The total costs for a turboexpander system include the equipment costs for the expander, gearbox, generator, pre- or post-heaters, utility interconnect and controls, and pipeline connection, as well as the overall engineering and installation costs. The costs for the systems listed in **Table 3** ranged from \$600 to \$2,300/kW (1987 dollars). The lowest cost per kW was on the largest system indicating that some economies of scale do exist. In general, however, experience has shown that the installations are very site specific and require significant custom engineering design, and do not lend themselves easily to the economies of prepackaged designs or standard configurations that might lower costs.<sup>22</sup>
- **Operating Costs** – Turboexpander installations generating electricity at city gates will have significantly higher operating costs than regulator stations. The highest cost will be in the fuel required for pre- or post-heating of the gas. Along with this are maintenance costs for the turboexpander equipment itself. A 1987 study by AGA estimated the annual non-fuel operating and maintenance (O&M) costs of the systems listed in **Table 3** at two percent of capital costs. It is likely that the incremental O&M costs of these systems would be similar to the O&M costs of the compressor heat recovery systems on a per kWh basis - \$0.001 to \$0.005/kWh.
- **Revenue from Power Sales** – As in the case of compressor heat recovery, the value of the electricity produced is the single most important factor in determining project economics. Overall economics appear marginal at power sales prices below \$0.05/kWh. The total revenue depends on the sales price and the amount of power generated. The amount of power is a function of the flow rate and pressure ratio at the location, and the efficiency of the expander/gearbox/generator system in converting pressure drop to electricity. Daily and seasonal variations in flow and pressure will affect power output and will most likely impact the value of the power to the ultimate purchaser.
- **Pressure Ratio** – The power recovery potential is roughly proportional to the natural logarithm of the pressure ratio (ratio of inlet pressure to outlet pressure). Higher pressure ratios result in higher power production. While normal pipeline operating pressures are well below maximum turboexpander pressure ratios, there is also a minimum pressure ratio (approximately 1.3:1) that must be maintained below which the turboexpander will not function.
- **Flow Rate** – Power output is also a function of flow rate. Variability in flow rate is an important consideration in project economics, and gas flow rates, particularly at city gate stations, will vary over a wide range due to seasonal, daily and hourly demand fluctuations. Turboexpanders can generally operate between 50 and 140 percent of design flow, although exact capabilities will vary from manufacturer to manufacturer. This can make optimum sizing for an installation difficult to estimate. Size the system too large and there may be significant periods of the year where flow (and pressure) are below the minimum requirements and the system will remain idle. Size the system too small and capital cost economies are lost and there may be extended periods where a significant portion of the flow will need to bypass the turboexpander.

Turboexpanders have been successfully used in LNG and natural gas processing plants because many of the limiting factors discussed above are absent. Flow rates and pressure drops in these facilities are constant or predictable. Process integration allows waste heat to be

---

<sup>22</sup> Personal communication with Stephen Gallowitz, Ridgewood Renewable Power.



used for gas heating, and in many cases the cooling effect of the gas expansion can be used elsewhere in the process.

***Based on a review of the limiting factors outlined above, the use of turboexpanders to recover power from pipeline to customer pressure drop is not economically viable in today's environment due to high capital costs, low value of the power produced, and wide and unpredictable variations in gas flow and pressure ratio that affect turboexpander performance.*** It should be noted that despite limited success, elements of the industry continue to periodically re-evaluate the economics and potential applicability of turboexpanders to the pipeline system. The most recent examples are demonstration projects underway in Canada and the United States incorporating fuel cell and turboexpander technologies (Enbridge, Connecticut Gas and FuelCell Energy). In these applications, waste heat from the fuel cell generator provides the preheat to the turboexpander system. These projects are supported by government funding and should be considered pre-commercial demonstrations.

It should be noted that improvements in the market-based drivers for compressor heat recovery identified in the previous section – power purchase prices that recognize and reward clean energy production, and modest incentives to the pipelines for their participation – would also improve the economic viability of turboexpander applications.

## V. APPLICATION OF TURBINE INLET AIR COOLING (TIC) FOR ENERGY RECOVERY

In a gas turbine, atmospheric air is compressed, heated by direct combustion, and then expanded to produce shaft power (see **Figure 3**). A portion of the power produced by the expander (also called the power turbine) drives the compressor and excess power is used to drive a generator or compressor. Ambient conditions affect both the power output and fuel efficiency of gas turbines. The rated performance of all gas turbines is based on standard ambient air conditions of 59°F and 14.7 psia at sea level, as selected by the International Standards Organization (ISO). Both power and efficiency decline as inlet air temperature increases above 59°F. Power output decreases due to a reduction in the mass flow of air into the turbine (the density of air declines as temperature increases), and efficiency decreases because the compressor requires additional power to compress warmer air. At inlet air temperatures of near 100°F, turbine power output can be 10 to 25 percent below ISO-rated power depending on turbine configuration.<sup>23</sup> The effect on efficiency is somewhat less pronounced, with efficiency decreases of 4 percent or less over ISO-rated performance at inlet air temperatures of 100°F.

**Figure 3. Components of a Simple-Cycle Gas Turbine**

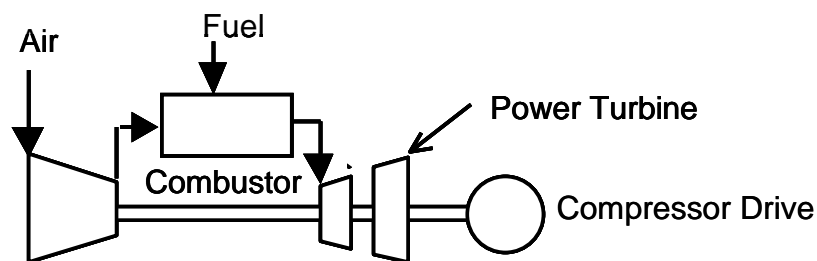

The impact of air temperature on turbine performance can be a significant issue in the power generation industry. The lower power and efficiency of gas turbines at high ambient temperatures means that gas turbine performance is at its lowest at the time power is often in greatest demand and most valued. One solution is to cool the air before it enters the turbine. This can be an economical approach in some situations because the increased power output derived from inlet cooling is greater than the power needed to cool the air.

The primary benefit of turbine inlet cooling (TIC) is that it allows the operator to reduce or prevent loss of power output when ambient temperature rises. A secondary benefit of TIC is that it also reduces the decrease in fuel efficiency (increase in heat rate) at high ambient temperatures. The economics of TIC systems are driven primarily on recovering lost turbine power output during periods of high value peak demand. **While TIC is used in the power industry to increase power output during peak summer periods, it has not been applied to pipeline compressors in the United States because there is no parallel constraint on pipeline compressor capacity.** Summer natural gas consumption is rising due to increased use of natural gas for power generation, but the delivery levels, **generally**, have not been constrained by limits on compressor capacity.

<sup>23</sup> *Unearthing Hidden Treasure: Combustion Turbine Inlet Air Cooling*, Dharam Punwani, Craig Hurlbert, Power Engineering, November 2005.

## A. EVAPORATIVE AND REFRIGERATION COOLING

There are two technological approaches to TIC:

- Evaporative cooling: wetted media, fogging, and wet compression/overspray; and
- Refrigeration cooling: electrical and absorption chillers.

In evaporative cooling, water is sprayed directly into the inlet air stream and evaporation of the water cools the air. Evaporative cooling usually is the first technology to be considered for TIC. Evaporative technologies have the lowest capital and operating cost options. Evaporative cooling originated with media type systems (inlet air is exposed to a film of water in a wetted media) and progressed to the more efficient fogging technologies (water is added to the inlet air in the form of a spray of very fine droplets) that are most often used today. Evaporative technologies can cool the inlet air to within 85 to 98 percent of the difference between the ambient dry-bulb and wet-bulb temperature. The water used for fogging (direct injection of very fine droplets of water into the turbine inlet) or wetting the medium may require treatment, depending upon the quality of water. The primary disadvantage of evaporative cooling is that the extent of cooling is limited by the wet-bulb temperature and is, therefore, weather dependent. Evaporative cooling works most efficiently during hot and dry weather and is less effective when ambient humidity is high. Evaporative cooling also consumes large amounts of water.

With refrigeration cooling, either a mechanical compressor-driven or thermally activated (absorption chiller) refrigeration cycle cools the inlet air through a heat exchanger. The heat exchanger in the inlet air stream causes an additional pressure drop in the air entering the compressor, thereby slightly lowering cycle power and efficiency. However, with the inlet air now substantially cooler than the ambient air, there is a significant net gain in power. Mechanical-driven chiller systems can cool the inlet air to much lower temperatures than those possible with evaporative cooling and can maintain any desired inlet air temperature down to as low as 42°F, independent of ambient wet-bulb temperature. The mechanical chillers used in TIC systems are usually driven by electric motors. The primary disadvantage of electrical chiller systems is that they are capital cost intensive and have high parasitic loads (0.70-0.80 kW/RT<sup>24</sup>) that lead to higher overall heat rates (reduced overall energy efficiency) for the turbine system than those for the evaporative cooling technologies.

Absorption cooling systems are similar to the electrical chiller systems except that instead of using mechanical chillers, these systems incorporate absorption chillers that use thermal energy (steam or hot water generated from the turbine exhaust) as the primary source of energy, and therefore require much less electric energy than the mechanical chillers. Absorption cooling systems can be used to cool the inlet air to about 50°F. Absorption chillers can be single-effect or double-effect. The single-effect absorption chillers use hot water or 15-psig steam (18 lb/hr-RT) while the double-effect chillers require less steam (10 lb/hr-RT) but need the steam at higher pressure (115 psig). A key advantage of absorption systems is that they have much less parasitic load (0.25 to 0.28 kW/RT) than electric chillers; their major disadvantage is increased complexity and higher capital cost than even mechanical refrigeration systems.

There are no known applications of electrical or absorption chiller TIC on pipeline compressor gas turbines in the United States. Successful application of TIC is limited to power generation

---

<sup>24</sup> RT is Refrigerated Ton – 12,000 Btu/hr of cooling.

applications where the need for capacity is greatest and the output of the turbine is lowest during hot weather (and the value of the power produced is highest).<sup>25</sup> In general, the pipeline system in North America is a winter peaking system, and there are no widespread compressor capacity shortages in summer. Developers of TIC systems indicate that the economics of TIC are generally not positive without a strong capacity driver (i.e., efficiency benefits are minimal to negative and rarely offset capital costs). ***Additionally, the absorption chiller TIC system is the only approach that utilizes waste heat, but the overall efficiency benefits of applying absorption chillers to gas turbine compressor drives are negative because of the parasitic electric loads for the absorber and cooling tower equipment. Specifically, the minimal improvement in fuel efficiency of the turbine is more than offset by the chiller parasitic electric loads of 0.26 to 0.28 kWh/RT.***

---

<sup>25</sup> Personal communications with Dharam Punwani, President of the Turbine Inlet Air Cooling Association.

## VI. OVERALL CONCLUSIONS

The analysis identified applications where heat recovery to power can be and is being economically applied to the pipeline system, but turboexpanders and turbine inlet air cooling do not appear to be viable options under current conditions. Specific findings include:

- Waste heat recovery to power systems are economically viable in areas where power purchase prices include some incentive for clean energy (e.g., states where heat recovery qualifies as an option under a renewable portfolio standard), and where compressor capacity and load factor are both above certain minimums. There are currently six operating waste heat to power projects on pipelines in North America (all based on organic Rankine cycles) with more than ten additional systems under development. Near term applications are limited to gas turbine drives which have higher exhaust temperatures and flows and are typically larger in size than internal combustion engine drives. Project economics are affected by turbine size and load factor, and the economic feasibility of these projects can be evaluated with more certainty as a retrofit on existing compressor stations that have available operating histories. Minimum hurdles for economic projects based on current technologies and power prices are total station gas turbine capacity of at least 15,000 hp and station operation at or more than 5,250 hours per year over the previous 12 months. About 90 to 100 compressor stations in the United States meet these hurdles, representing approximately 500 to 600 MW of potential power generation capacity.
- Turboexpanders have been successfully used in LNG and natural gas processing plants for many years. Flow rates and pressure drops in these facilities are constant or predictable, and process integration allows waste heat from the process to be used for gas heating, and in many cases the cooling effect of the gas expansion can be used elsewhere in the process. There are currently no known commercial turboexpander installations generating electricity at city gates in the U.S. pipeline system. Projects have not been economically viable due to a combination of high capital cost, low purchased power prices and wide variations in flow and pressure ratio at pressure reduction stations that negatively impact turboexpander performance. The industry periodically re-evaluates the applicability of turboexpanders on the pipeline system, and some limited demonstrations are currently underway integrating fuel cells for preheating of the gas. These projects are all supported by government research funds and are pre-commercial demonstrations.
- While turbine inlet air cooling is used in the power industry to increase power output during peak summer periods, it has not been applied to pipeline compressors in the United States because there is no parallel constraint on pipeline compressor capacity. Summer natural gas consumption is rising due to increased use of natural gas for power generation, but the delivery levels generally have not been constrained by limits on compressor capacity. Additionally, the absorption chiller TIC system is the only approach that utilizes waste heat, but the overall efficiency benefits of applying absorption chillers to gas turbine compressor drives are negative because of the parasitic electric loads for the absorber and cooling tower equipment. Specifically, the minimal improvement in fuel efficiency of the turbine is more than offset by the chiller parasitic electric loads of 0.26 to 0.28 kWh/RT.

**APPENDIX A**  
**List of Organizations Interviewed**

**Developers/Suppliers**

- Caterpillar
- Ormat Technologies
- Recycled Energy Development
- Ridgewood Renewable Power
- Solar Turbines
- TAS
- PRC International
- Turbine Inlet Air Cooling Association

**Pipelines/Gas Industry**

- Alliance
- CenterPoint
- Kinder Morgan
- NiSource
- Northern Natural Gas
- TransCanada/Northern Border
- Spectra Energy
- Williams
- Keyspan Energy